

Canopy
Mini Pure'line 90 cm
White

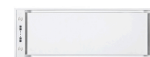

EAN 5414425008216

Energy label

▪ Energy Efficiency class (EElhood)	B
▪ Annual Energy Consumption (kWh/year) (AEChood)	56,6
▪ Fluid Dynamic Efficiency class (FDEhood)	A
▪ Lighting Efficiency class (LEhood)	A
▪ Grease Filtering Efficiency class (GFEhood)	D

Functions & features

▪ Control method	Push buttons + Remote control
▪ Number of speeds	3 + power
▪ Automatic Power revert (minutes)	6
▪ Motor	Integrated
▪ Sound absorber	Integrated
▪ Recirculation	Optional
▪ InTouch function	Standard
▪ Delayed switch off (minutes)	10
▪ Number of grease filters	1
▪ Grease filter	7400020
▪ Grease filter cleaning indication	▪
▪ Recirculation filter cleaning indication	▪

Dimensions

▪ Product dimensions (WxDxH) (mm)	860 x 301 x 330
▪ Width flange (mm)	10
▪ Dimensions cut-out opening (WxD) (mm)	845 x 286
▪ Min dimensions cabinet (WxDxH) (mm)	x 600 x
▪ Advised mounting height induction hobs (Hmin-Hmax) (mm)	650 - 850
▪ Advised mounting height gas hobs (Hmin-Hmax) (mm)	650 - 850
▪ Advised mounting height ceramic hobs (Hmin-Hmax) (mm)	600 - 850
▪ Diameter outlet (mm)	150
▪ Position exhaust	Right, Top, Left, Back, Front

Lighting

▪ Functional lighting type	Led
▪ Dimmable light	▪
▪ Soft-ON/OFF	▪
▪ Total energy consumption functional light (W)	8
▪ Color functional light	2700/4000

Airflow and noise level

▪ Free airflow (m³/h)	720
▪ Airflow (m³/h) measured according to EN 61591	
▪ Sound regulation according to EN 60704-2-13	

Airflow and noise level

▪ Airflow duct out speed 1 (m ³ /h) / Max pressure duct out speed 1 (Pa)	269 / 434
▪ Airflow duct out speed 2 (m ³ /h) / Max pressure duct out speed 2 (Pa)	369 / 480
▪ Airflow duct out speed 3 (m ³ /h) / Max pressure duct out speed 3 (Pa)	493 / 514
▪ Airflow duct out max powerspeed (m ³ /h) (Qboost) / Max pressure duct out max powerspeed (Pa)	674 / 549
▪ Sound pressure duct out speed 1 (dB(A)) / Sound power duct out speed 1 (dB(A))	29 / 41
▪ Sound pressure duct out speed 2 (dB(A)) / Sound power duct out speed 2 (dB(A))	36 / 48
▪ Sound pressure duct out speed 3 (dB(A)) / Sound power duct out speed 3 (dB(A))	43 / 55
▪ Sound pressure duct out at max powerspeed (dB(A)) / Sound power duct out at max powerspeed (dB(A)) (LWAboost)	51 / 63

Technical specifications

▪ Maximum power (W)	247
▪ Voltage cooker hood (V)	230
▪ Frequency (Hz)	50
▪ Length power supply cord (m)	1,3
▪ Power consumption in stand-by-mode (Ps) (W)	0.25
▪ Net weight (kg)	11,9

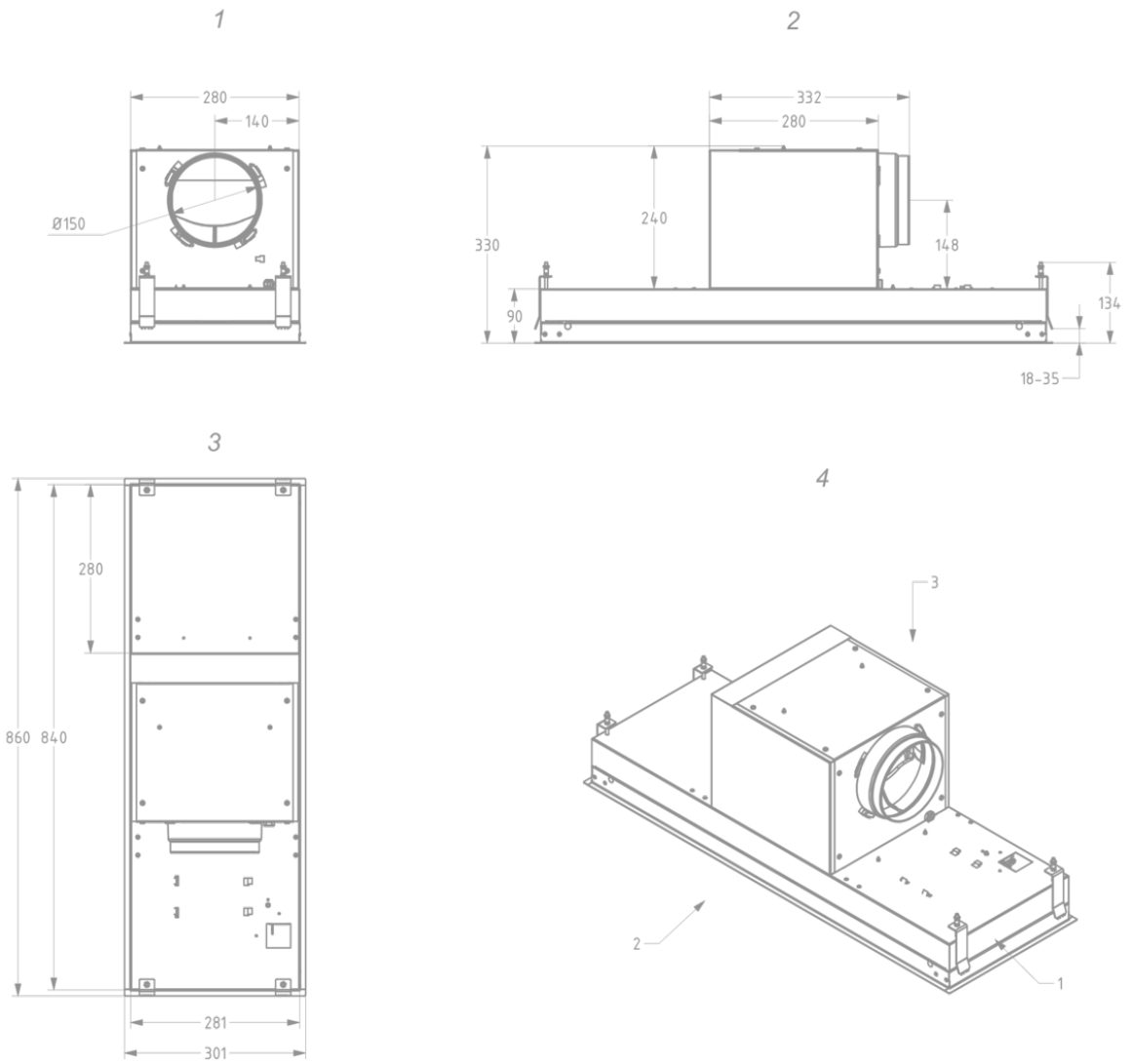

Accessories

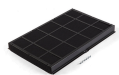
Recirculation kit

820400

Recirculation set Mini Pureline 820, 821, 826

Recirculation box

841400

recirculation box with monoblock white (270x500mm)



842400

recirculation box with monoblock black (270x500mm)

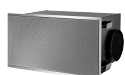

843400

recirculation box with monoblock grey (270x500mm)

Control kit

990030

Control kit for external lighting or valve

